

LL26.14 MK2

CAPACITY 230 KG
(2 persons 80x2=160 kg + tool box 70 kg)

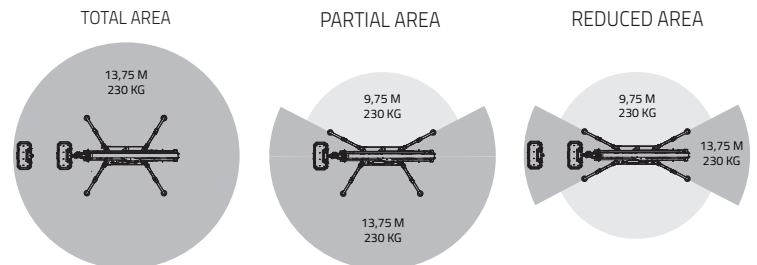
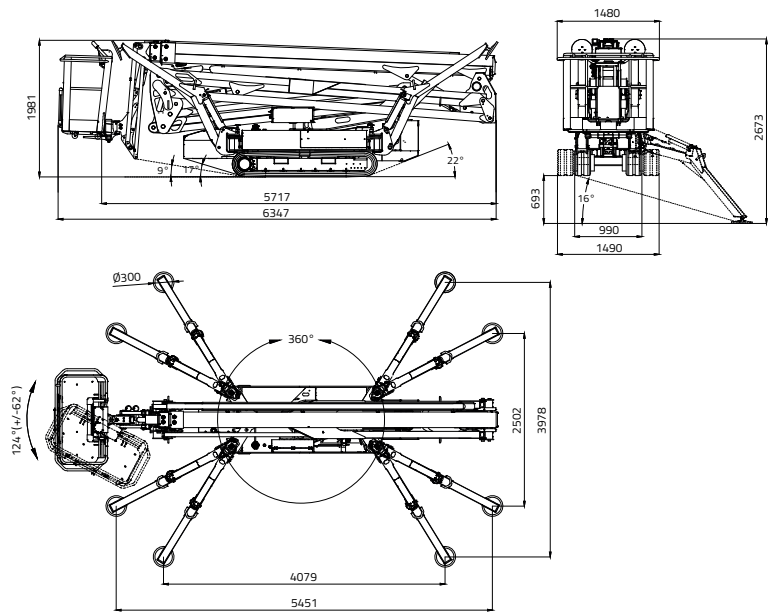
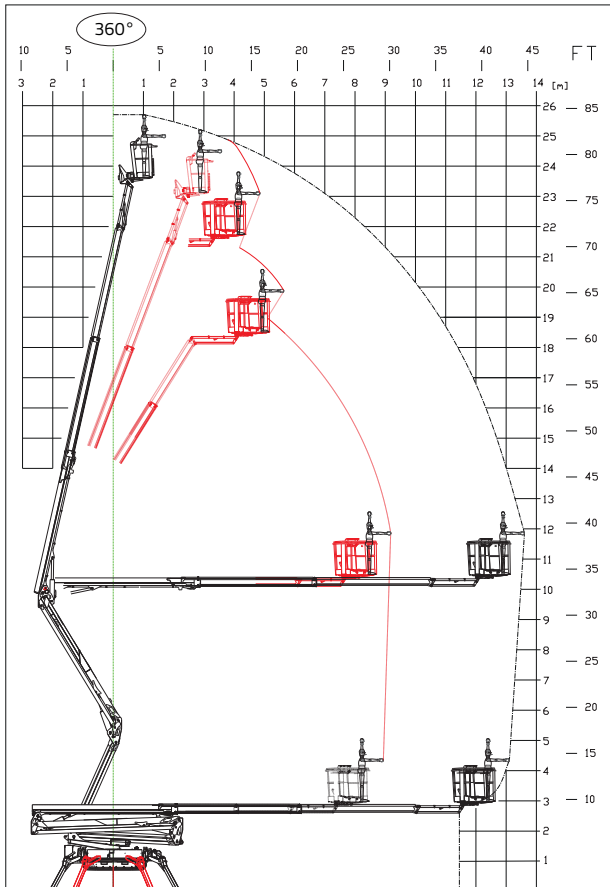

25,70 m

13,75 m ■ 9,75 m (REDUCED AREA)

6,34 m

5,72 m

1,98 m

1.335 x 690 x h. 1.100 mm

124° (+/-62°)

16° / 28,7%

990 - 1490 mm

3124 daN - 4,42 daN/cm²

Variable stabilization area:
- 4.079 x 3.978 mm (total)
- 5.451 x 2.502 mm (narrow)

Automatic set up system III S std.

Remote control

GPRS-GPS

R.A.H.M.

Lithium-ion battery pack 9,2 kWh

Bi-energy (Diesel + Lithium-ion battery pack)

LL26.14 *MK2*



DIESEL ENGINE

Brand..... KUBOTA
 Type D902 Autorev
 Pistons no. and displacement.....No. 3 / 898 cm³
 Max gross power
21,6 HP - 16,1 kW @ 3200 rpm
 Electrical start..... 12 volt

LITHIUM-ION SYSTEM

Lithium-ion powered.....9,2KWh
 Onboard battery charger.....
 220V or 110V+-30V 50-60 Hz
 Autonomy4/5 h
 Recharge time on flat batteries
4 h (indicative)
 Recharge time to 80% on flat batteries.....
2 h (indicative)

HYDRAULIC PUMPS

Electric motorno. 2 gear pumps

TRACKED UNDERCARRIAGE

Track tensionergrease-filled
 Rollers no. per side6 + slide

Translation speed with 2nd auto2speed:

- diesel engine 1,1 - 2 km/h
 - lithium-ion system.....0,7 - 1,2 km/h

WEIGHT MACHINE:

- diesel engine4.365 kg
 - lithium-ion system.....4.384 kg
 - bi-energy system4.560 kg

MAX WIND SPEED 12,5 m/s