

HS701 SELF-LOADING AND EXTRA HIGH-TIP VERSION

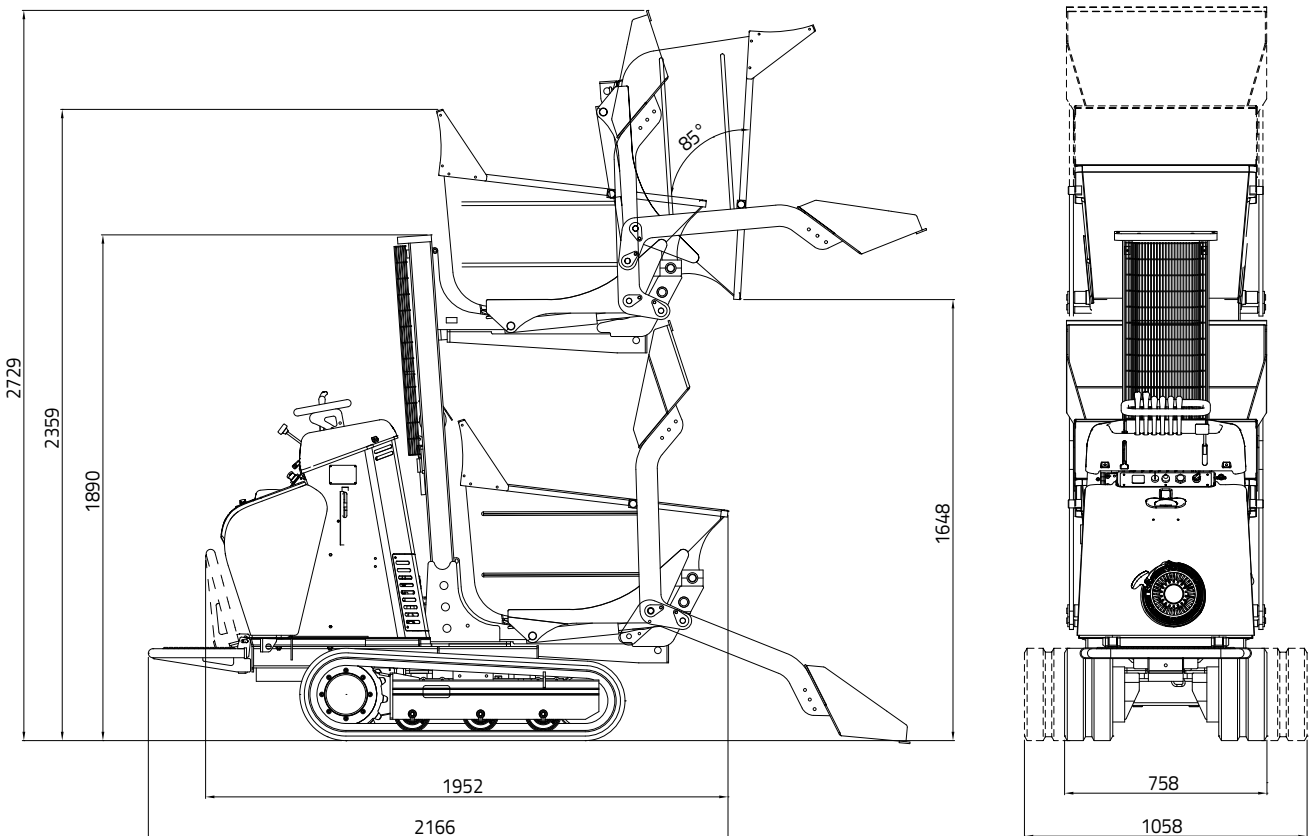

HS701

SELF-LOADING AND EXTRA HIGH-TIP VERSION

PETROL ENGINE

Brand and type.....Honda GX390
 Pistons and displacementsingle-cylinder 389 cc
 Max gross power11,7 HP - 8,7 kW @ 3600 rpm
 Startingelectric 12 volt
 Fuel tank5,3 liters
 Granted noise levelLwa 99 dB

DIESEL ENGINE

Brand and type.....KUBOTA OC 95
 Pistons and displacementsingle-cylinder 416 cc
 Max gross power9,4 HP - 7,0 kW @ 3600 rpm
 Startingelectric 12 volt
 Fuel tank5,5 liters
 Granted noise levelLwa 101 dB

DISTRIBUTOR

Type mechanical

HYDRAULIC PUMPS

Number and typen° 3 gear pumps

TRACKS

Track tensioner.....grease
 Track width180 mm
 Rollers per side3
 Undercarriage width open/close758 - 1058 mm

PERFORMANCE

Translation speed petrol engine2,8 - 4 km/h
 Translation speed diesel engine2,2 - 3,3 km/h
 Max. inclination15° (dumper bed lowered)
 Capacity460 kg

DUMPER BED CAPACITY

Rated volume (ISO 6483)0,25 m³
 Struck volume0,19 m³

OPERATING WEIGHT (without operator)

Petrol engine852 kg
 Diesel engine876 kg