

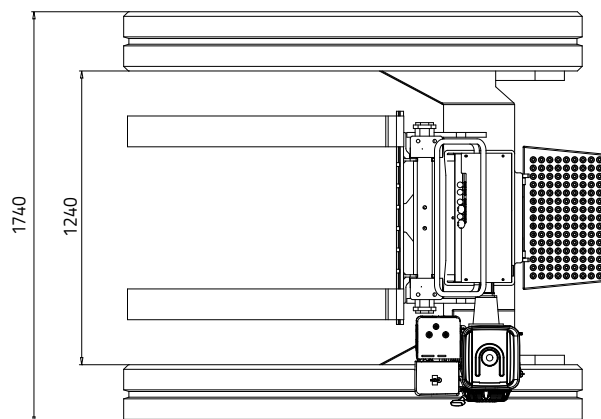

TRANSPALLET CINGOLATO TP2000

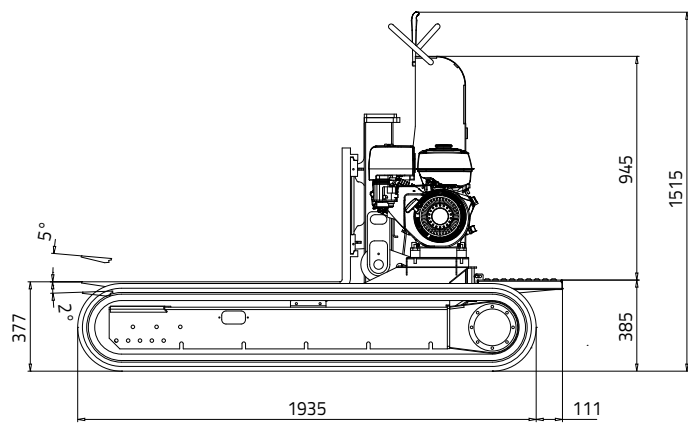

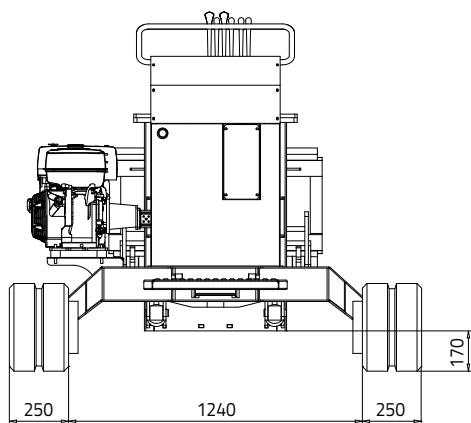
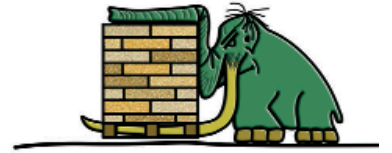

TRANSPALLET CINGOLATO TP2000

MOTORE BENZINA

MotoreHONDA
TipoGX390
Cilindri e cilindratamonocilindrico da 389 cc
Potenza lorda max11,7 HP - 8,7 kW @ 3600 rpm
Regime di taratura3500 rpm
Avviamentoa strappo

DISTRIBUTORE

Tipomeccanico

POMPA IDRAULICA

Tipo e numeroad ingranaggi n° 3 x 4 cc
Portata litri minuto15 lpm

MOTORIDUTTORE

Tipoorbitale
Cilindrata100 cc

CINGOLATURA

Tendicingoloa grasso
Larghezza cingolo250 mm
Rulli per lato5
Velocità di traslazione1,5 - 2,2 km/h
Carreggiata fissa1740 mm
Portata nominale2000 kg
Pendenza max superabile in senso longitudinale e trasversale20° (36,4%)

PESO OPERATIVO (escluso operatore)845 kg

SERBATOIO CARBURANTE

Benzina6,5 litri