

# HS701 CONSTRUCTION VERSION

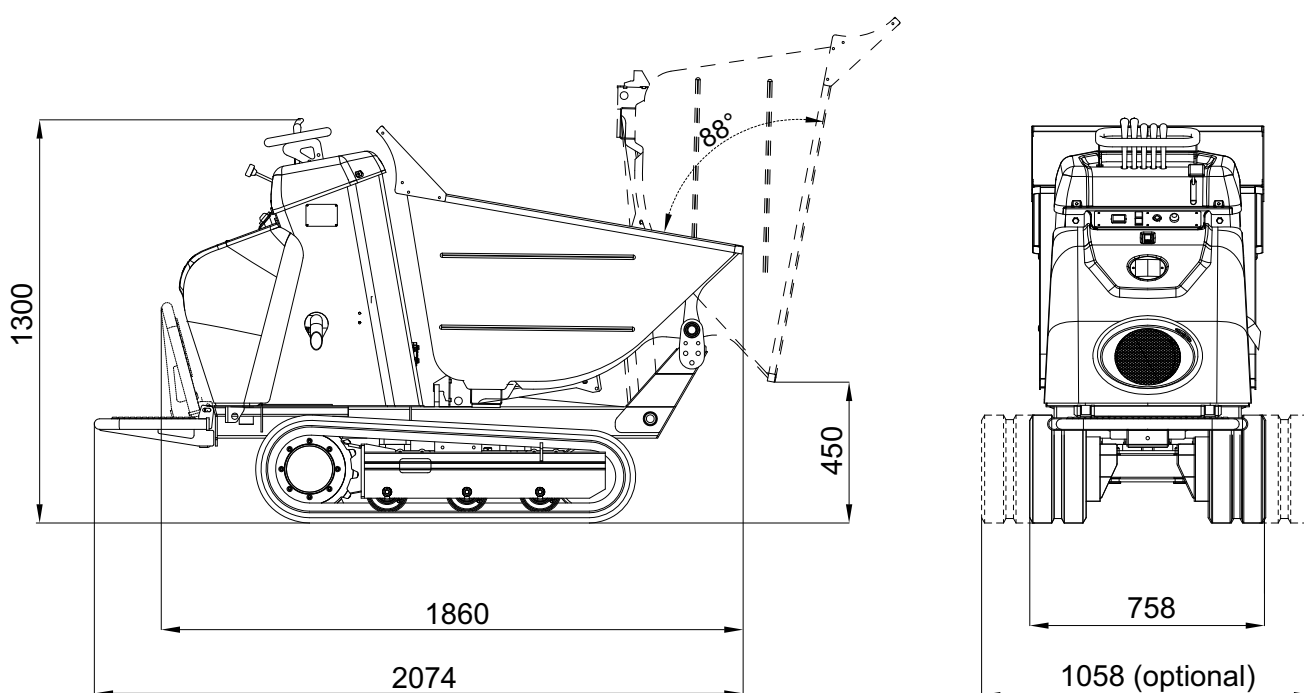

# HS701

## CONSTRUCTION VERSION

### PETROL ENGINE

Brand and type.....Honda GX270  
Pistons and displacement.....single-cylinder 270 cc  
Max gross power.....8,4 HP - 6,3 kW @ 3600 rpm  
Starting .....manual  
Fuel tank .....5,3 liters

### DIESEL ENGINE

Brand and type.....KUBOTA OC 95  
Pistons and displacement.....single-cylinder 416 cc  
Max gross power.....9,4 HP - 7,0 kW @ 3600 rpm  
Starting .....electric 12 volt  
Fuel tank .....5,5 liters

### DISTRIBUTOR

Type ..... mechanical

### HYDRAULIC PUMPS

Number and type .....n° 3 gear pumps

### TRACKS

Track tensioner.....grease  
Track width .....180 mm  
Rollers per side .....3  
Undercarriage width open/close .....758 - 1058 mm

### PERFORMANCE

Translation speed petrol engine .....2,2 - 3,3 km/h  
Translation speed diesel engine .....2,2 - 3,3 km/h  
Max. inclination .....20° (diesel version)  
Granted noise level .....Lwa 101 dB

**CAPACITY**..... 700 kg

### DUMPER BED CAPACITY

Rated volume (ISO 6483) .....0,34 m<sup>3</sup>  
Struck volume .....0,28 m<sup>3</sup>

### OPERATING WEIGHT (without operator)

Fixed/widening undercarriage - petrol engine.....540 kg / 620 kg  
Fixed/widening undercarriage - diesel engine.....580 kg / 660 kg