

# TELECRAWLER13N

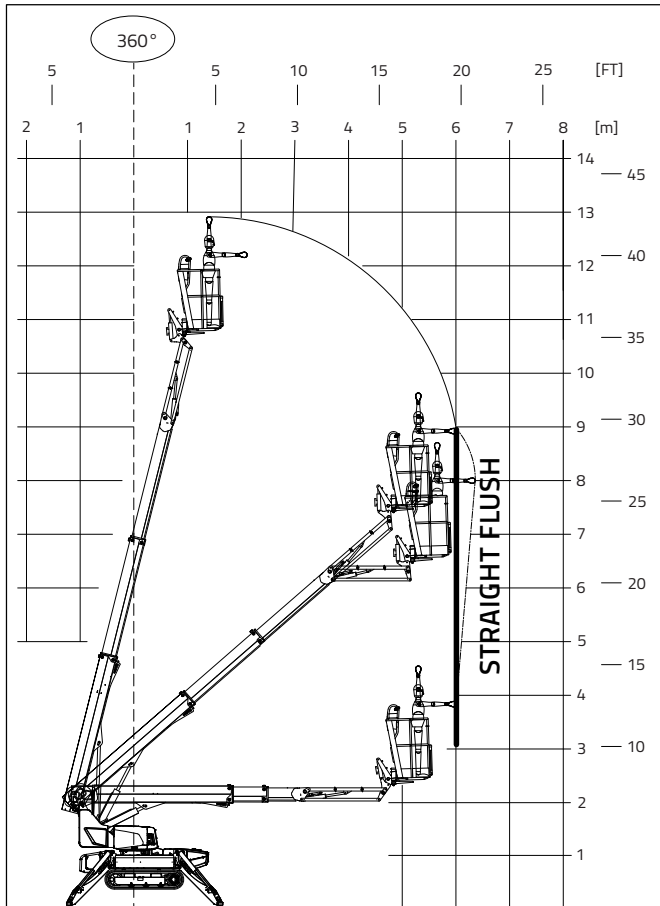

**CAPACITY 136 kg**  
(1 person 80 kg + tool box 56 kg)

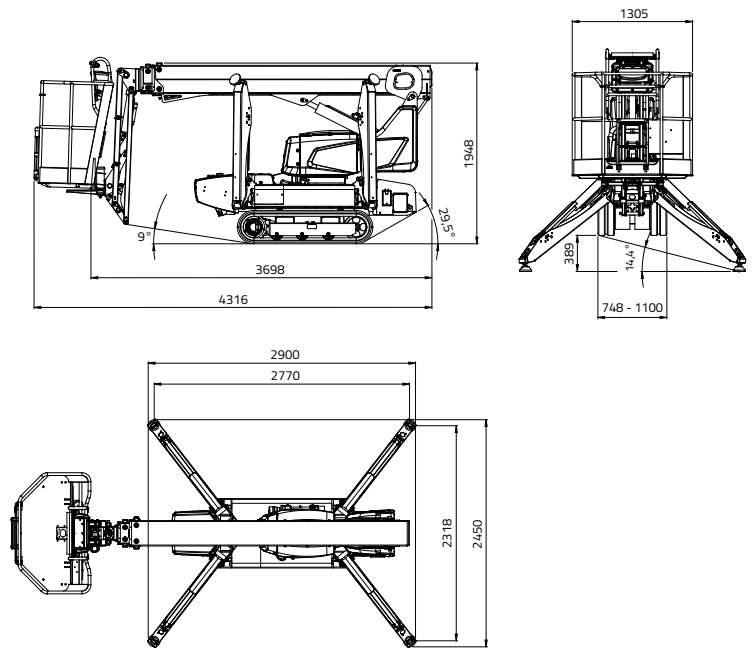

12,90 m



6,40 m



4,316 m



3,698 m



1,948 m



1305 x 600 x h1100 mm



16° / 28,7%



748 - 1100 mm



1334 daN - 10,1 daN/cm<sup>2</sup>



2900 x 2450 mm



Automatic set up system IIS std.



Remote control



GPRS-GPS



R.A.H.M.

# TELECRAWLER13N



## LITHIUM-ION SYSTEM

Lithium-ion powered.....	4,15 kWh
Electric motor :	
- rated voltage.....	48 V
- rated power.....	2 kW
Onboard battery charger.....	220V +-30V 50-60Hz / 110V +-30V 50-60Hz
Autonomy.....	4-5 h
Recharge time on flat batteries.....	4 h (indicative)
Recharge time to 80% on flat batteries.....	2 h (indicative)

## ELECTRIC MOTOR

Standard.....	230V / 50 Hz - 2,2 kW
Optional.....	110V / 50 Hz - 2,2 kW

## TRACKED UNDERCARRIAGE

Track tensioner.....	grease-filled
Rollers no. per side.....	3 + slide
Translation speed.....	1,3 - 2,3 - 3,2 km/h

WEIGHT MACHINE..... 1.895 kg

MAX WIND SPEED..... 12,5 m/s