

TELECRAWLER13N

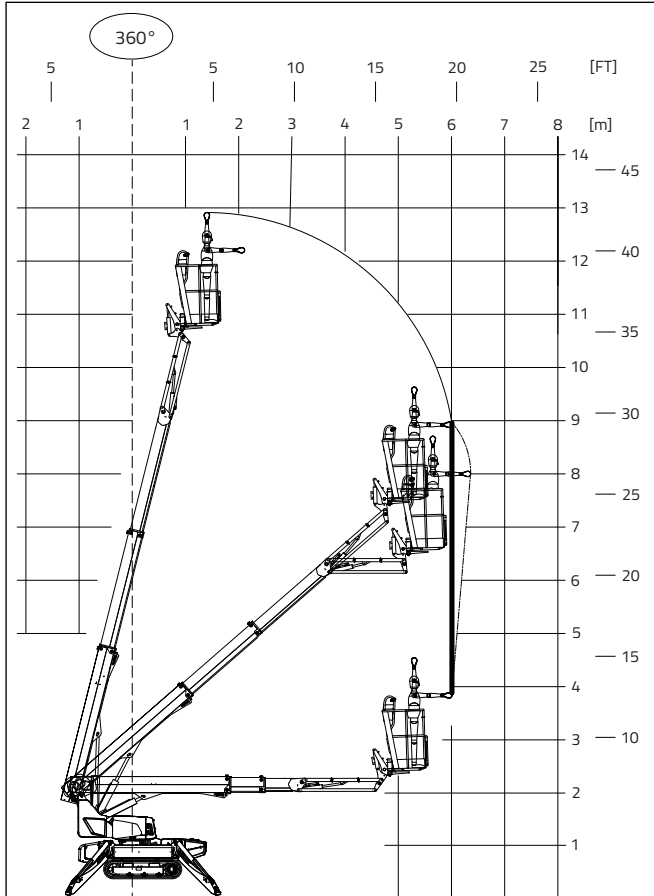

PORTATA 136 KG
(1 persona 80 kg + attrezzatura 56 kg)

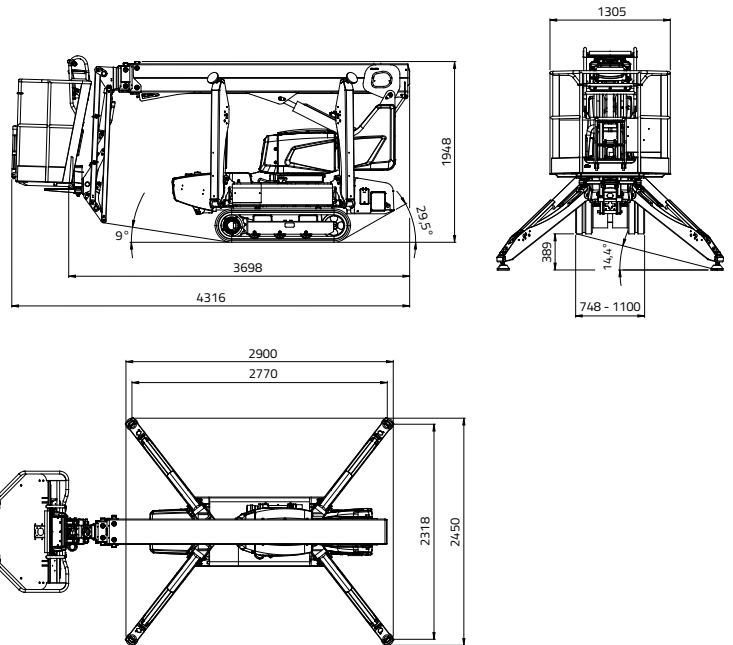

12,90 m



6,40 m



4,316 m



3,698 m



1,948 m



1305 x 600 x h1100 mm



16° / 28,7%



748 - 1100 mm



1334 daN - 10,1 daN/cm²



2900 x 2450 mm



Stabiliz. e destabiliz. automatica IIIS di serie



Filocomando



GPRS-GPS



R.A.H.M.

TELECRAWLER13N



SISTEMA LITHIUM-ION

Pacco batterie al litio	4,15 kWh
Motore elettrico :	
- tensione nominale.....	48 V
- potenza nominale.....	2 kW
Caricabatterie a bordo.....	220V +-30V 50-60Hz / 110V +-30V 50-60Hz
Autonomia di lavoro.....	4-5 h
Tempo di ricarica a batterie completamente scariche.....	4 h (indicativo)
Tempo di ricarica all'80% da batterie completamente scariche.....	2 h (indicativo)

MOTORE ELETTRICO

Standard	230V / 50 Hz - 2,2 kW
Optional	110V / 50 Hz - 2,2 kW

CINGOLATURA

Tendicingolo	a grasso
Rulli per lato	3 + slitta
Velocità di traslazione	1,3 - 2,3 - 3,2 km/h
PESO MACCHINA	1.895 kg
VELOCITÀ MAX VENTO	12,5 m/s