

TELECRAWLER13N

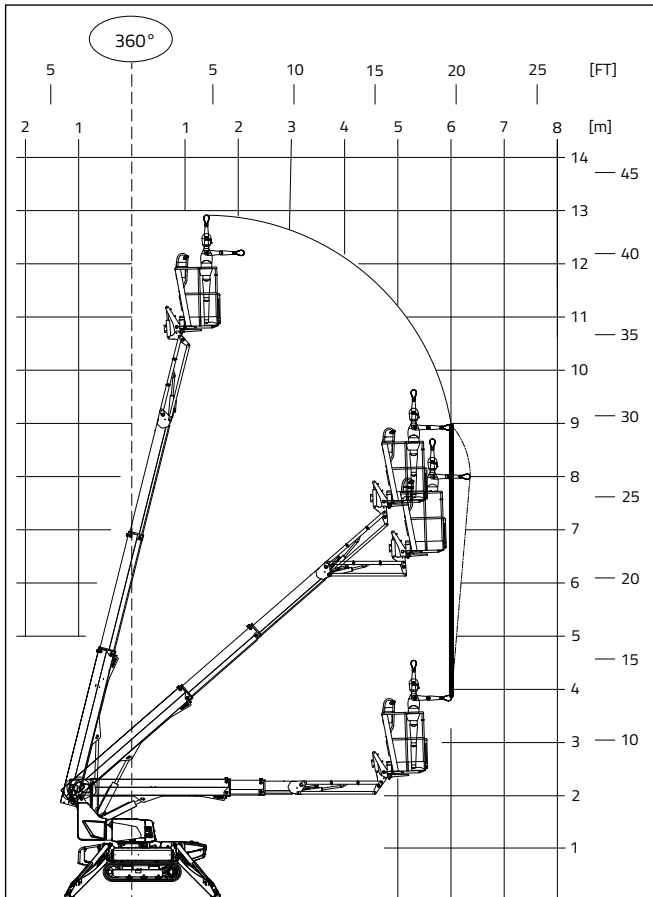

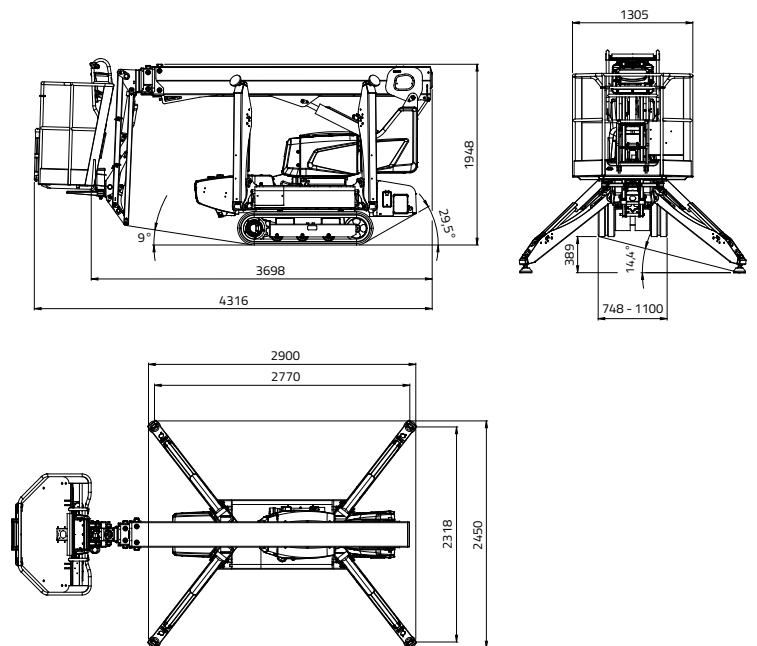



MAX. KORBTRAGLAST 136 KG
(1 Person 80 kg + Werkzeugkasten 56 kg)



-  12,90 m
-  6,40 m
-  4,316 m
-  3,698 m
-  1,948 m

-  1305 x 600 x h1100 mm
-  16° / 28,7%
-  748 - 1100 mm
-  1334 daN - 10,1 daN/cm²
-  2900 x 2450 mm

-  IIS –Abstütz- und Einfahrtomatik serienmässig
-  Kabelfernbedienung
-  GPRS-GPS
-  R.A.H.M.

TELECRAWLER13N



ELEKTROMOTOR MIT LITHIUM-BATTERIEN

Lithium Akkupack	4,15 kWh
Elektromotor :	
- Nennspannung	48 V
- Nennleistung	2 kW
Batterielader an Bord	220V +-30V 50-60Hz / 110V +-30V 50-60Hz
Arbeitsautonomie	4-5 h
Ladezeit bei komplett leeren Batterien	4 h (Schätzwert)
Ladezeit bis 80% bei komplett leeren Batterien	2 h (Schätzwert)

ELEKTROMOTOR

Standard	230V / 50 Hz - 2,2 kW
Optional	110V / 50 Hz - 2,2 kW

RAUPENFAHRWERK

Kettenspanner	mit Schmierfett
Stützrollen pro Seite	3 + Schlitten
Fahrgeschwindigkeit	1,3 - 2,3 - 3,2 km/h

MASCHINENGEWICHT 1.895 kg

MAX. WINDGESCHWINDIGKEIT 12,5 m/s