

CAPACITY 120 KG

(1 person 80 kg + toolbox 40 kg)

CAPACITY 200 KG

(2 persons 80x2=160 kg + toolbox 40 kg)

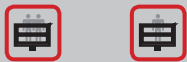
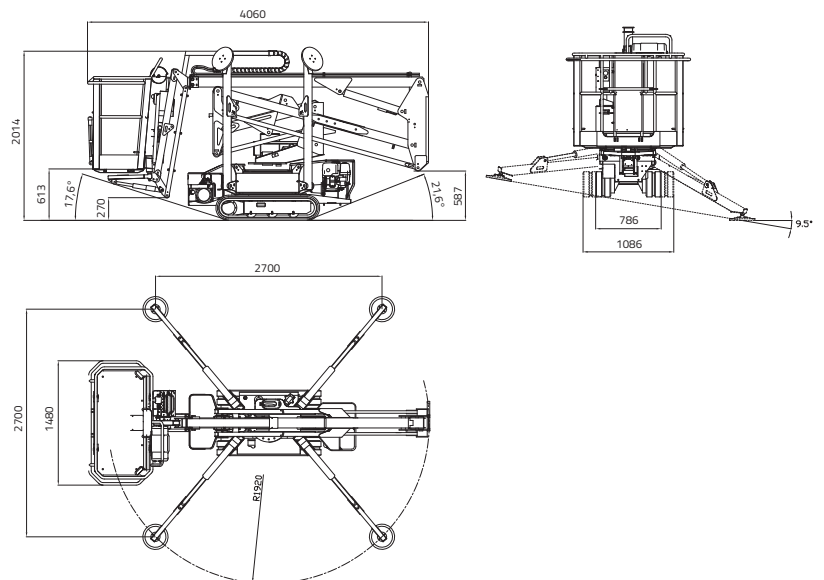

12,68 m 14,00 m



5,66 m 7,00 m



4,06 m



3,87 m



2,01 m



1.335 x 690 x h 1.100 mm



15° / 26,8%



786 - 1086 mm



1330 daN - 1,9 daN/cm²



2700 x 2700 mm



Automatic set up system IIS std.



Radio control



GPRS-GPS



R.A.H.M.



Lithium-ion battery pack
4,8 kWh
Optional



PETROL ENGINE

Brand.....HONDA
 TypeGX390
 Pistons no. and displacement.....
 single-cylinder 389 cm³
 Max gross power
 11,7HP - 8,7 kW @ 3600 rpm (GX390)
 Electrical start 12 volt

DIESEL ENGINE

Brand..... HATZ
 Type 1B40 - HD Autorev
 Pistons no. and displacement.....
 single-cylinder 462 cm³
 Max gross power
 10 HP - 7,5 kW @ 3600 rpm
 Electrical start 12 volt

LITHIUM-ION SYSTEM

Lithium-ion powered 4,8 kWh
 Onboard battery charger.....
 220V 50Hz or 110V 50Hz
 Autonomy..... 4-5 h
 Recharge time on flat batteries
4 h (indicative)
 Recharge time to 80% on flat batteries.
 2 h (indicative)

ELECTRIC MOTOR

Standard 230V / 50 Hz - 2,2 kW
 Optional 110V / 50 Hz - 2,2 kW

TRACKED UNDERCARRIAGE

Track tensioner grease-filled
 Rollers no. per side 3 + slide

Translation speed:

- thermal engine 1,4 - 2,8 km/h
 - lithium system..... 1,2 - 2,4 km/h

WEIGHT MACHINE petrol / diesel engine 1700 kg

WEIGHT MACHINE lithium system 1810 kg

MAX WIND SPEED..... 12,5 m/s